

LOC		DIST		REVISIONS			
P	LTR	DESCRIPTION	DATE	DN	APVD		
B		ECO-07-019669	23AUG2007	LAM	PR		

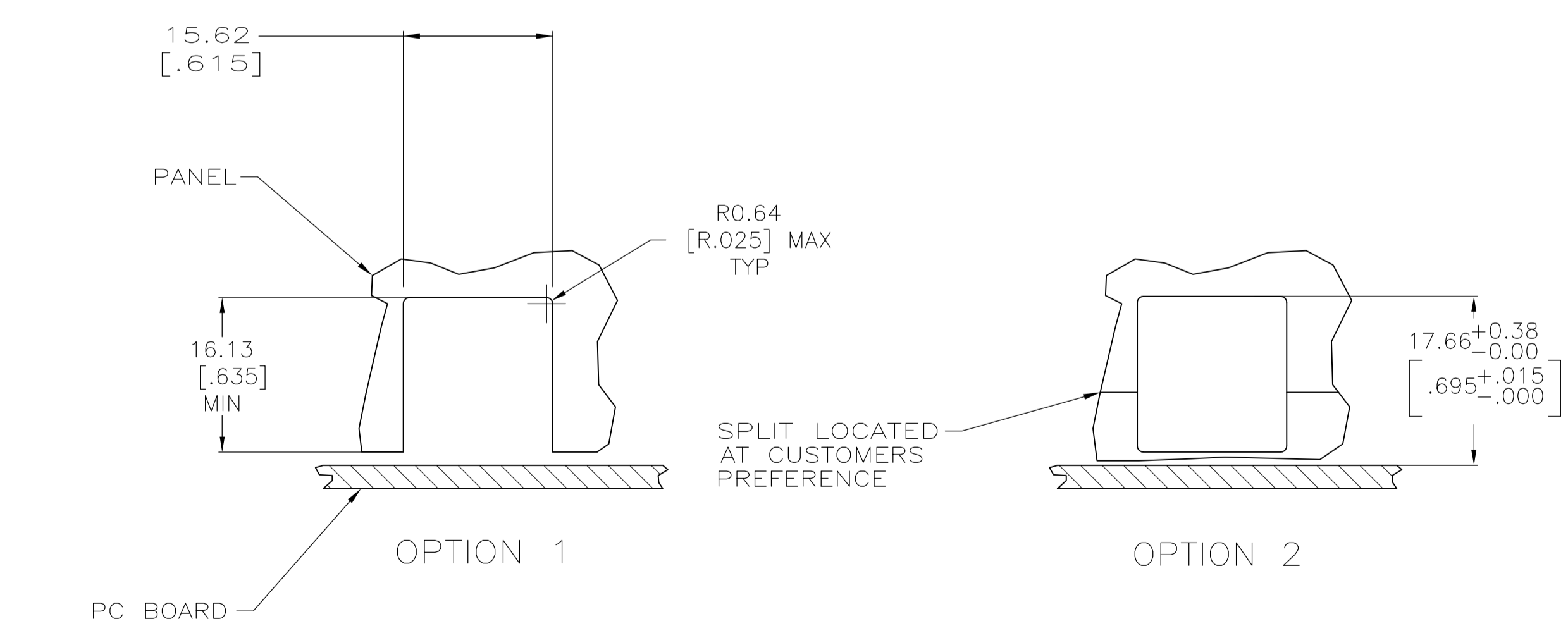

RECOMMENDED PANEL CUTOUT
SCALE 2:1

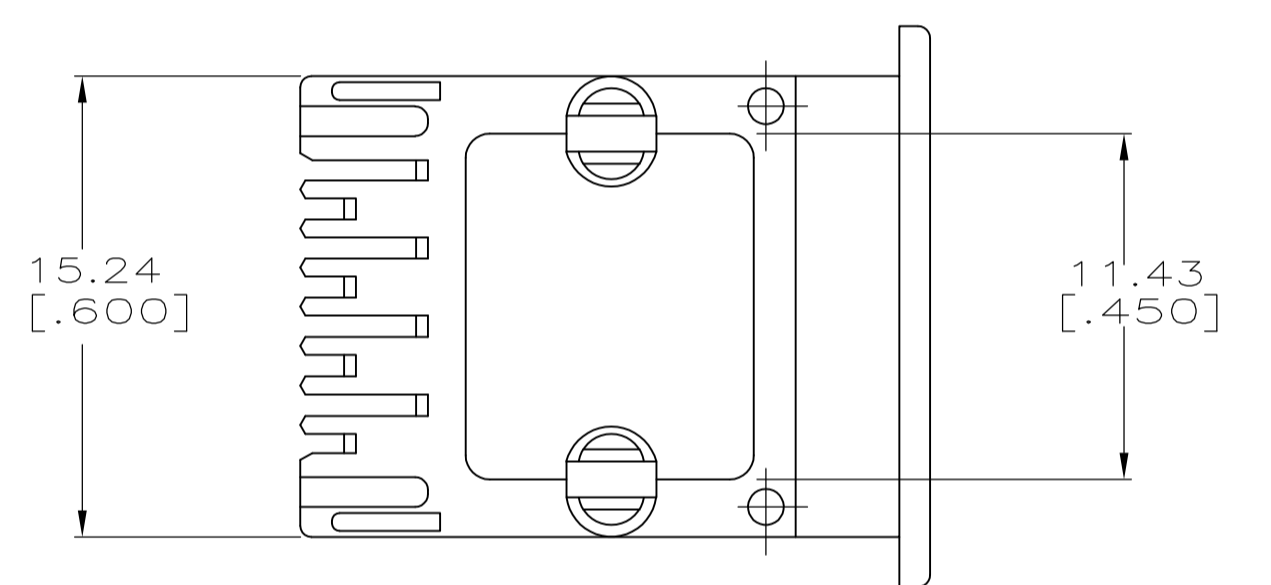
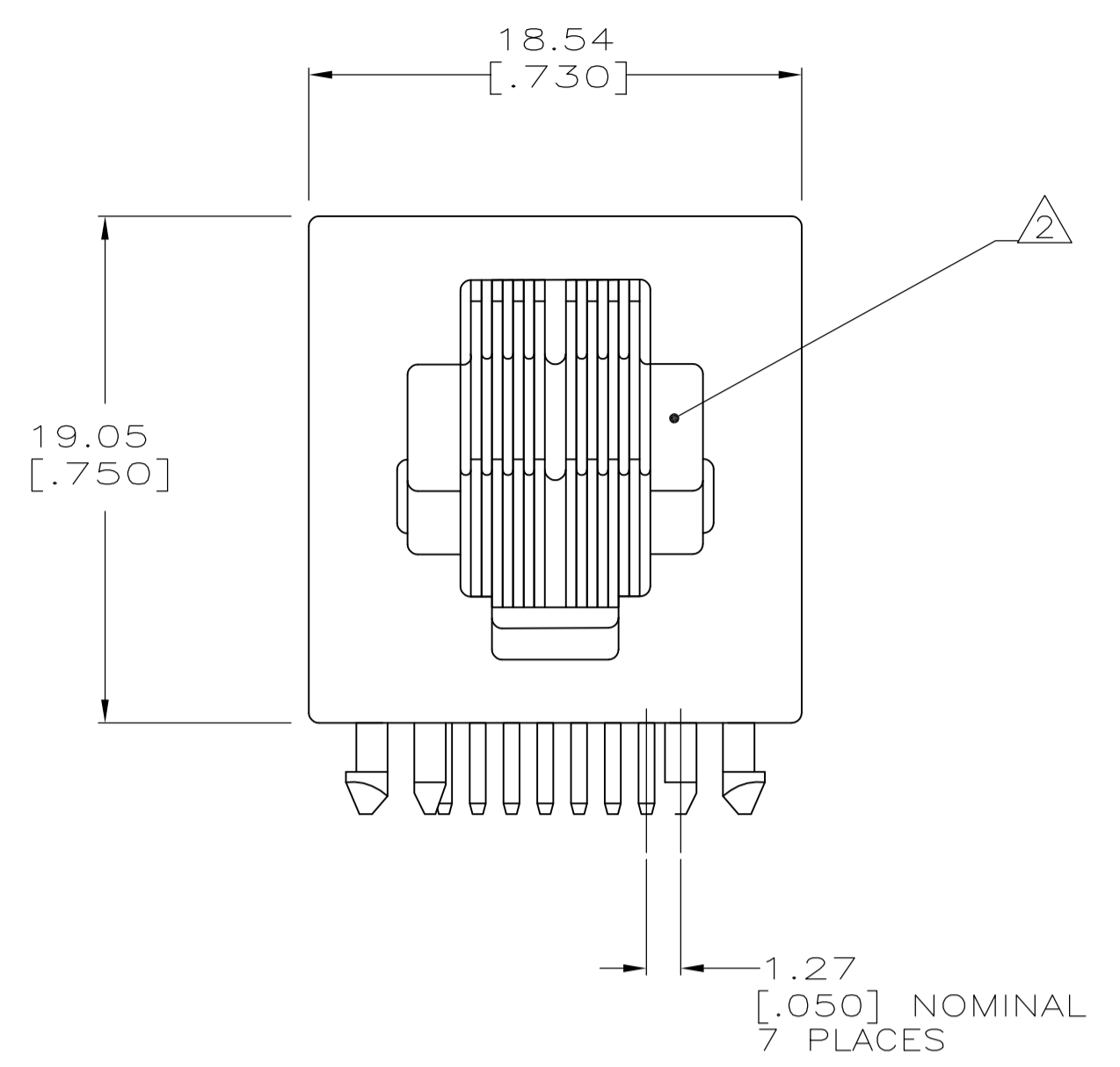
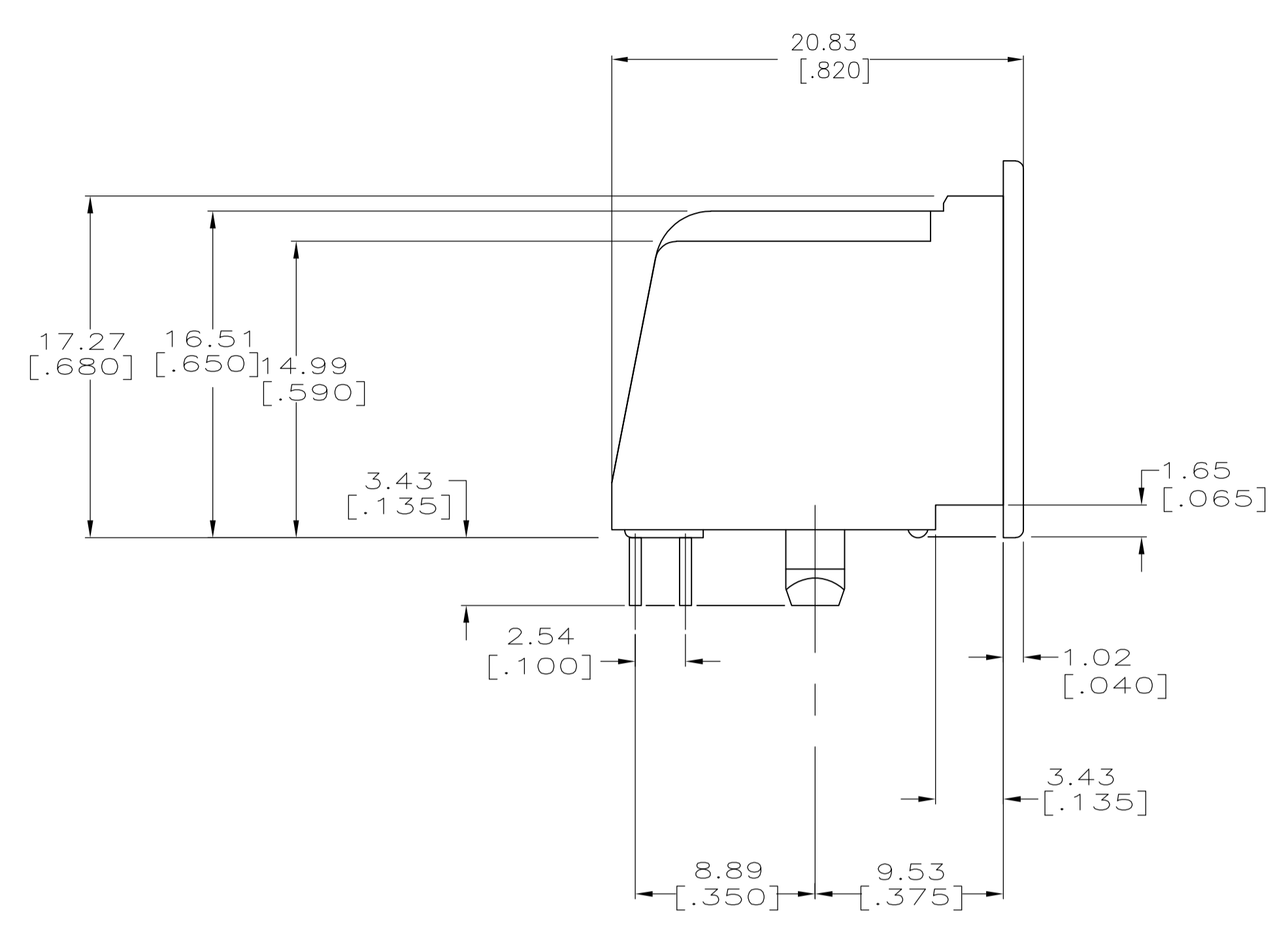
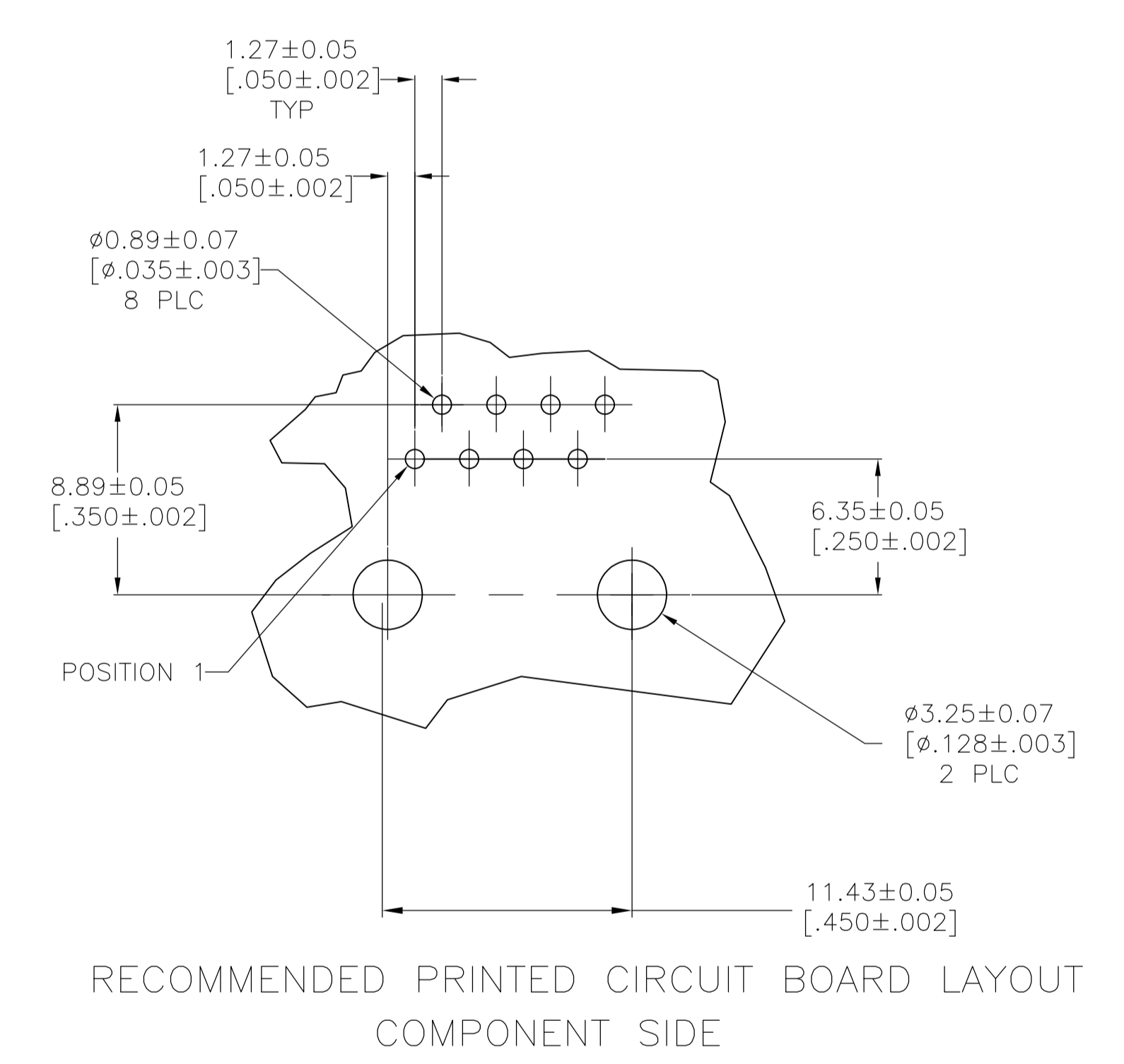

RECOMMENDED PRINTED CIRCUIT BOARD LAYOUT
COMPONENT SIDE

- MATERIAL: HOUSING - PBT POLYESTER, BLACK.
 TERMINAL - 0.36 [.014] THICK PHOS BRONZE
 PLATED WITH 1.27 μm [.000050] MINIMUM THICK HARD
 GOLD IN LOCALIZED GOLD PLATE AREA & 3.81 μm
 [.000150] MINIMUM THICK MATTE TIN IN SOLDER AREA
 OVER 1.27 μm [.000050] MINIMUM THICK NICKEL UNDERPLATE.
- △ CAVITY CONFORMS TO FCC RULES AND REGULATIONS
 PART 68 AND REA BULLETIN 345-81, PE-76
 SPECIFICATIONS FOR MODULAR TELEPHONE HARDWARE.

8	5520243-4
CONTACTS	PART NO

THIS DRAWING IS A CONTROLLED DOCUMENT.		DIN J. ALCORTA - 17JUN2005		Tyco Electronics Corporation	
DIMENSIONS: mm [INCHES]		DOCK 5 17JUN2005		Harrisburg, Pa 17105-3608	
TOLERANCES UNLESS OTHERWISE SPECIFIED:		DCK J. WESTMAN 17JUN2005		Tyco Electronics	
0 PLC ± -		APVD S. FLICKINGER 17JUN2005		NAME PRINTED CIRCUIT BOARD	
1 PLC ± -		PRODUCT SPEC 108-1163		MODULAR JACK ASSEMBLY, SIDE ENTRY,	
2 PLC ± -		APPLICATION SPEC 114-2048		8 POSITION, FLANGED	
3 PLC ± 0.13 [.005]		SIZE CAGE CODE DRAWING NO		RESTRICTED TO	
4 PLC ± -		A1 00779 C=5520243		-	
ANGLES ± -		WEIGHT		-	
MATERIAL SEE NOTE 1		FINISH SEE NOTE 1		CUSTOMER DRAWING	
		SCALE 4:1		SHEET 1 OF 1	
				REV B	