

1 2 3 4 5 6 7 8

A

B

C

D

F

A

B

C

D

E

F

修訂 Revision

記號 MARK	版本 REV.	修訂內容 DESCRIPTION	變更單 ECN	日期 DATE	繪圖 DWN.
	2.2	新增 ADD BSO		DEC 08 2008	但雪嬌
	2.3	依APOP文件修改特殊特性符號 Ⓐ變更為Ⓐ Ⓢ變更為▽		NOV 09 2009	王蘭花
△1	2.4	新增62545200BWS ADD 62545200BWS		SEP 12 2013	黎靜
	3.0	更換南京雕刻HL6		JUN 13 2018	張樊
△2	3.1	新增62545200KSS	THEN-18253	APR 30 2019	張樊
△3	3.2	材料Brass變更為Copper alloys	THEN-19276	DEC 31 2019	張樊

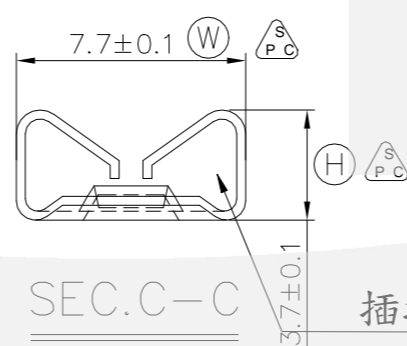
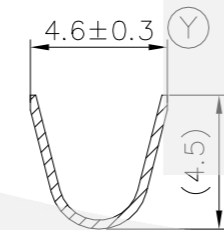
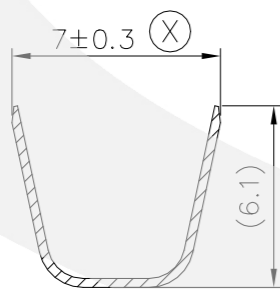
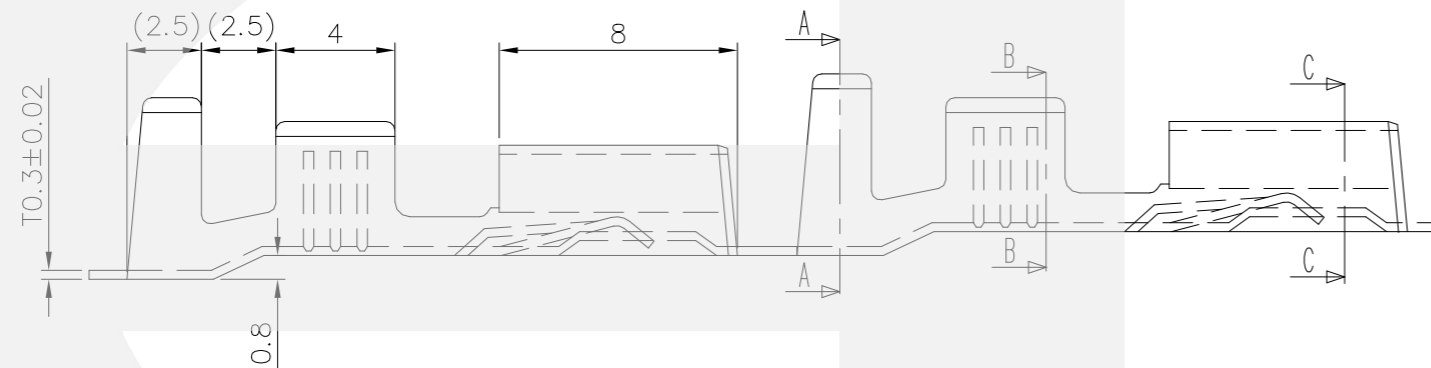
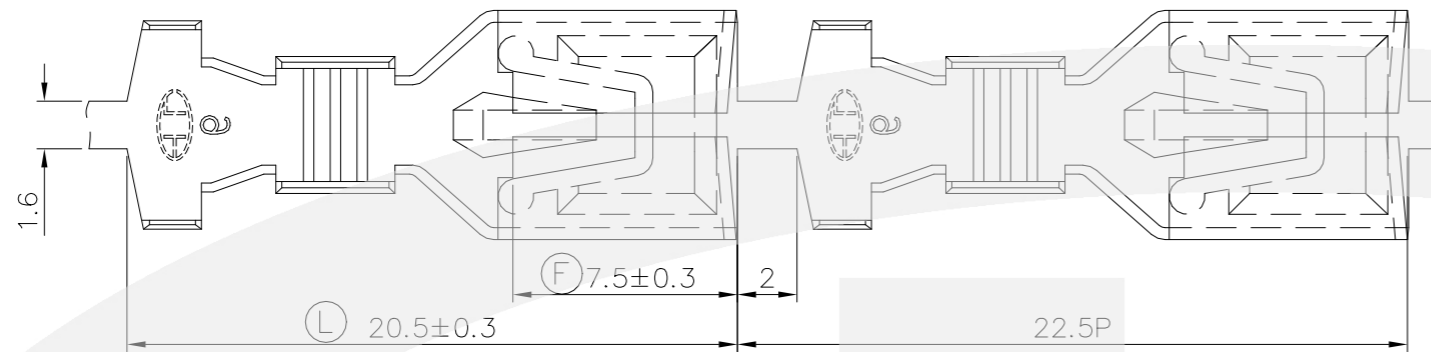

插拉力

說明1:
 1.預鍍錫,膜厚40u"-70u"
 2.素材
 3.對手件:250型 TAB=0.8mm
 BSS:
 插入力: 0.5~1.5KGF
 拉拔力: 0.6~1.5KGF
 BSO:
 插入力: 0.6~1.5KGF
 拉拔力: 0.6~1.5KGF

NOTE1:
 1.PRE-TIN PLATED THICKNESS
 40u"-70u"
 2.MATING PART: 250-TYPE TAB=0.8mm
 BSS:
 INSERTED FORCE :0.5~1.5KGF
 TENSILE FORCE :0.6~1.5KGF
 BSO:
 INSERTED FORCE :0.6~1.5KGF
 TENSILE FORCE :0.6~1.5KGF

Hu Lane Associate Inc. 產品規格圖 A



NO.	產品編號 Part Number	材料 Material	表面處理 Surface Treatment	線徑 Wire Range
4	62545200KSS	Copper alloys	Note 1	3.0mm ²
3	62545200BWS	Brass	Note 1	3.0mm ²
2	6616424BS0	Brass	Note 2	3.0mm ²
1	6616424BSS	Brass	Note 1	3.0mm ²

材料 MATERIAL		SEE TABLE				AUTO CAD	
表面處理 FINISH		SEE NOTE					
核發單位 ISSUED BY	制定單位 INSTITUTED BY	核准 APPROVED BY	審核 CONFIRMED BY	制定 DRAWN BY	繪圖 DRAWER		
 2019.12.31 研發部	 2019.12.31 研發部	 2019.12.31 研發部	 2019.12.31 研發部				

一般公差 Tolerances unless other specified
<1.0 : ± 0.10
1.0-5.0 : ± 0.15
5.0-10.0 : ± 0.20
10.0-20.0 : ± 0.25
20.0-45.0 : ± 0.30
>45.0 : ± 0.50
ANGLE : ± 2.0°

胡連精密股份有限公司
 Hu Lane Associate Inc.

圖名 DRAWING NAME
 250 TYPE FEMALE TERMINAL

圖號 DRAWING NUMBER
 616424

圖紙 size : A3 單位 Unit : mm 比例 Scale : 6/1 頁數 Sheet : 1/1 CODE : S11

1 2 3 4 5 6 7 8